

# IRON ISOTOPES AND LIFE

**Brian Beard and Clark Johnson**

In 1996 Dave McKay and co-workers from NASA published a paper in *Science*, which suggested that a Martian meteorite contained evidence for past life on Mars. One of their most compelling lines of evidence for extraterrestrial life was the presence of small grains of magnetite that had the same shape and size produced by magnetotactic bacteria. These purported magneto fossils spurred us to hypothesize that it may be possible to use the isotopic composition of iron to evaluate if an iron-bearing mineral such as magnetite was produced by an organism or if it was produced by abiological processes. Our hypothesis was that the relatively small mass differences between Fe isotopes, and the fact that most bonds between iron atoms and adjacent anions are highly ionic in nature<sup>1</sup>, would produce minimal isotopic fractionation of Fe in abiologic processes. In contrast, we hypothesized that an organism would be able to exploit the small differences in bonding produced by even small mass differences among Fe isotopes producing a measurable isotopic shift.

At the time, there was almost no information on the isotopic composition of iron. Previous studies had not been able to identify naturally occurring mass dependent fractionation, within the error of the mass spectrometry measurements<sup>2</sup>. Therefore it was necessary to develop new analytical methods that were highly precise. In our first published studies of Fe isotopes we reported on the analytical methods that we developed to document that igneous rocks had a constant Fe isotope composition, that chemically precipitated sediments such as banded iron formations had different Fe isotope compositions, and that reduction of ferric oxide minerals by iron-reducing bacteria produced aqueous ferrous iron that had a significantly different Fe isotope composition as compared to the starting ferric oxide minerals. The results of this research were important because they demonstrated, for the first time, that there are Fe isotope variations in nature and that biological processing of Fe produces isotopic fractionation. The results of this work spurred significant research into this field, and to date over 75 peer-reviewed papers have been published on Fe isotopes from more than twenty laboratories in North America, Europe, Asia, and Australia. These groups are conducting Fe isotope studies to investigate topics in the medical and nutritional sciences, nanoscale material sciences, and, of course, cosmochemistry, microbiology, and geochemistry. Although the field of Fe isotopes is currently in its developmental stage, much like oxygen isotopes was five decades ago; it is rapidly becoming a common geochemical tool.



Figure 1: Tom Lapen, René Wiesli, and Nancy Mahlen tuning the multi-collector ICP mass spectrometer.

At Wisconsin, our work has progressed from the initial studies, which were an analytical challenge that required using microgram-quantities of Fe for an analysis with a relative isotope ratio precision of 0.3 per mil and a throughput of 10 samples in a week, to its current form where we can analyze nanogram quantities of Fe (1000 times smaller) to a precision of 0.05 per mil with a throughput of 100 samples in a week. The increase in precision, decrease in sample size, and the rapidity at which samples can be analyzed have allowed us to work on a wide variety of projects. Some of the most important research that we have conducted has been on experimental studies that investigate Fe isotope exchange rates and the magnitude of Fe isotope fractionation between two or more phases in both biological and abiological systems. This work has included investigating isotopic fractionation and exchange between dissolved Fe and iron oxide and carbonate minerals and between aqueous ferrous and ferric species. This work has been spearheaded by a talented group of Badger alumni, including former graduate students Rebecca Poulson (BS '02; MS '05) Heidi Crosby (MS '05), post-doctoral fellow Joe Skulan (MS '93), two academic staff scientists, Sue Welch and René Wiesli, and extensive collaborations with current UW faculty member Eric Roden. Each study that we have conducted has required 100's of Fe isotope analyses for each experiment and would have been impossible without new analytical facilities, including a new mass spectrometer (Figure 1) and instrumentation room (in 2000), as well as extensive remodeling of the clean room laboratory (in 2004) (Figures 2 & 3). Seed funds for these initiatives came from University and Alumni funds, and to date these have been matched by \$2,500,000 in external research grants for Fe isotope studies.

Experimental determinations of Fe isotope fractionation factors, coupled with theoretical calculations, has made it



Figure 2: Aaron Shultis and Nancy Mahlen working in the newly renovated clean chemistry lab.

possible to begin to unravel the origin of Fe isotope compositions determined on samples from the rock record<sup>3</sup>. For example, it has been possible to use these fluid and mineral fractionation factors to evaluate the genesis of banded iron formations (BIF). BIF are the major repository of iron ore and these sequences largely formed in the Archean and Early Proterozoic (e.g., greater than 1.8 billion years ago). A century ago, the exploitation of BIF helped drive the Wisconsin economy and build our department. We have analyzed over 300 minerals from banded iron formations for Fe isotope compositions in research projects that have involved former UW G&G Alumni including Julie O'Leary (BS '99), Lauren Hubbard (BS '04), Elizabeth Valaas (MS '04), and Joe Skulan, as well as Professor John Valley. Most analyses are from drill cores in BIF that have not been subjected to significant metamorphism, such as the core shown in Figure 4. Based on the fractionation factors that we have experimentally determined in the laboratory we can calculate the composition of fluids that precipitated these iron minerals. The Fe isotope composition of these fluids suggest that they were mixtures of Fe derived from hydrothermal fluids and Fe derived from dissimilatory iron-reducing bacteria. Thus, there was a major biological component in the formation of some BIF, a subject of great discussion over the years, but which definitive proof has been lacking. Additional work on Archean-age shales indicates that the dissimilatory iron-reducing biological signature is present in shales as old as 2.9 Ga thus indicating that this metabolic process has been in operation for over half of Earth's history. The goal of using Fe isotopes as a biosignature for ancient life clearly has been realized in ancient rocks such as banded iron formations.

Application of Fe isotopes as an astrobiological tool to explore if there is/was life on Mars and to evaluate Martian paleo-environmental conditions is still being pursued. In collaboration with Dr. Mahadeva Sinha from the NASA Jet Propulsion Laboratory, we are developing methods to conduct

isotopic analyses of H, C, Mg, O, S, Ca, and Fe using a robotic lander craft. These methodologies make use of a combination of thermal decomposition and reduction reactions, coupled with laser ablation techniques, to produce vapors of these elements that can be introduced into an electron impact ionization mass spectrometer. Pictured in Figure 5 is a miniature mass spectrometer developed by Dr. Sinha that is space-craft-mission capable. This mass spectrometer fits in the palm of your hand, weighs 0.9 kg, consumes 2-3 watts of energy when operational, and is capable of simultaneous analysis of

ions over a 40% mass range at a mass resolving power of 400 (approximately the same resolving power of the mass spectrometers on the 3rd floor of Weeks Hall).

In addition to instrumentation development, we have an active program that is devoted to "ground truthing" Fe isotope results in which plausible Martian-like environments are studied in order to gain experience in how to interpret isotopic measurements that may be made on the surface of Mars. These studies include:

- Investigation of iron-depositing hot and cool springs from Yellowstone National Park and Bloomington, Indiana, respectively, that were studied by Rebecca Poulson as part of her masters thesis, in collaboration with Sherry Cady from Portland State University, Beverly Pierson from Puget Sound



Figure 3: Heidi Crosby titrating acid in preparation for iron isotope analysis.

University, and Juergen Schieber from Indiana University;

- A hyper-saline algal mat community from Baja Mexico, that has been studied by Associate Scientist Sue Welch and post-doctoral fellow Silke Severmann, in collaboration with Dave DesMarais and other scientists from NASA Ames;



Figure 4: BIF drill core from the Kuruman Iron Formation, South Africa. Dark layers are composed of magnetite, light layers are siderite, and grey layers are composed of chert and hematite.

- Iron oxide concretions from the Navajo Sandstone that are morphological equivalents of the “blueberry” hematite concretions from Mar’s Meridiani Planum, in collaboration with Professor Marjorie Chan (PhD ‘82) from University of Utah;

- Extraterrestrial studies of meteorites from Mars and lunar samples that were studied by Assistant Scientist Rene Wiesli;

- Archean-age shales and paleosols, work that has been pursued by post-doctoral fellow Kosei Yamaguchi

- Teasing out the most ancient Fe isotope biosignatures in 3.8Ga banded iron formations from Isua, Greenland by current graduate student Morgan Herrick;

- Experimental investigations into the mechanisms involved in Fe isotope fractionations that are produced by dissimilatory iron-reducing bacteria as well as coupled bacterial sulfate and iron reduction by current graduate students Heidi Crosby and George “Buddy” Tangalos, respectively.

In all of these studies the goal is to determine the range of Fe isotope compositions that are preserved in minerals and fluids, and to constrain the relative roles of biologic and abiologic processes in iron cycling. Moreover, we seek to use this information to constrain paleo-environmental

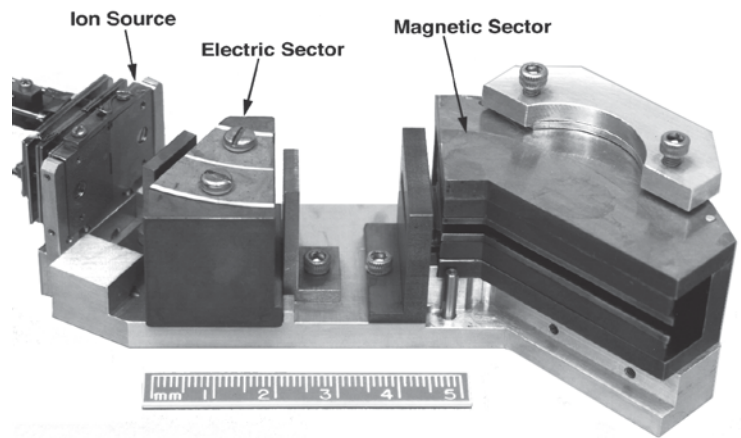

**Mattauch-Herzog Geometry: double focusing for all masses**

Figure 5: The Jet Propulsion Laboratory miniature mass spectrometer that can be used to conduct in situ isotopic analyses of Fe and other elements on the surface of Mars.

conditions such as the temperature at which minerals precipitated, iron oxidation rates as related to Eh and pH conditions, and the chemical compositions of ancient fluids.

The year 2006 marks a decade of Fe isotope research at Wisconsin. The coming decade promises exciting new discoveries on the origin and evolution of Fe-metabolizing bacteria on Earth and the possibility of remotely measuring these isotopic signatures on other planetary bodies.

Additional information on Fe isotope research at Wisconsin can be found at: <[http://www.geology.wisc.edu/~unstable/Research\\_Program.htm](http://www.geology.wisc.edu/~unstable/Research_Program.htm)>.

Footnotes:

<sup>1</sup> There are four naturally occurring stable iron isotopes <sup>54</sup>Fe (5.84%), <sup>56</sup>Fe (91.76%), <sup>57</sup>Fe (2.12%), and <sup>58</sup>Fe (0.28%). The 4% relative mass difference between <sup>54</sup>Fe and <sup>56</sup>Fe as compared, for example, to the 12% mass difference between <sup>16</sup>O and <sup>18</sup>O tends to make Fe isotope variations much smaller as compared to O isotopes. Moreover, ionic bonds tend to produce small isotopic fractionations as compared to bonds that are more covalent in nature.

<sup>2</sup> Coincidentally, one of the first studies of Fe isotopes was conducted in 1940 by George E. Valley Jr., father of John Valley. In this work it was shown that within the limits of the measurement technique at the time, the Fe isotope composition of iron meteorites was the same as terrestrial iron (Valley and Anderson, 1947, Journal of American Chemical Society).

<sup>3</sup> A recent review of Fe isotope geochemistry as well as other non-traditional stable isotopes such as Ca, Mg, and Cu has been published in Reviews in Mineralogy and Geochemistry, volume 55, edited by Clark Johnson, Brian Beard, and Francis Albarède, entitled Geochemistry of Non-Traditional Stable Isotopes.